

2013-12-25



5012625001-4P02

TP04P

Instruction Sheet

安 裝 說 明
安 裝 說 明

Text Panel PLC

文本顯示控制器

文本显示控制器



Thank you for choosing Delta TP series products. TP04P is composed of a text panel and a PLC. It supports abundant instructions. The capacity of the program memory it supports is 8K steps. TP04P features the same program download port shared by both PLC and TP editing software: WPLSoft/ISPSoft and TPEditor. It also offers various graphical objects for developing the program. The user can also obtain higher efficiency by purchasing additional extension cards, which increase the program portability and save the program download time. Please ensure to use TP series with Delta power supply module, DVPPS01, DVPPS02 or DVPPS05.

- EN ✗ TP04P is an OPEN-TYPE device. It should be installed in a control cabinet free of airborne dust, humidity, electric shock and vibration. To prevent non-maintenance staff from operating TP04P, or to prevent an accident from damaging TP04P, the control cabinet in which TP04P is installed should be equipped with a safeguard. For example, the control cabinet in which TP04P is installed can be unlocked with a special tool or key.
- EN ✗ DO NOT connect AC power to any of I/O terminals, otherwise serious damage may occur. Please check all wiring again before TP04P is powered up. After TP04P is disconnected, Do NOT touch any terminals in a minute. Make sure that the ground terminal ⊕ on TP04P is correctly grounded in order to prevent electromagnetic interference.
- FR ✗ TP04P est un module OUVERT. Il doit être installé que dans une enceinte protectrice (boîtier, armoire, etc.) saine, dépourvue de poussière, d'humidité, de vibrations et hors d'atteinte des chocs électriques. La protection doit éviter que les personnes non habilitées à la maintenance puissent accéder à l'appareil (par exemple, une clé ou un outil doivent être nécessaire pour ouvrir a protection).
- FR ✗ Ne pas appliquer la tension secteur sur les bornes d'entrées/Sorties, ou l'appareil TP04P pourra être endommagé. Merci de vérifier encore une fois le câblage avant la mise sous tension du TP04P. Lors de la déconnection de l'appareil, ne pas toucher les connecteurs dans la minute suivante. Vérifier que la terre est bien reliée au connecteur de terre ⊕ afin d'éviter toute interférence électromagnétique.

■ Product Outline and Dimensions

• Front Panel

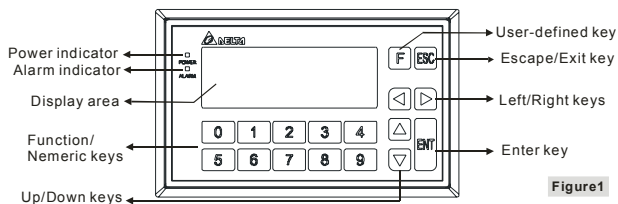

• Back Panel

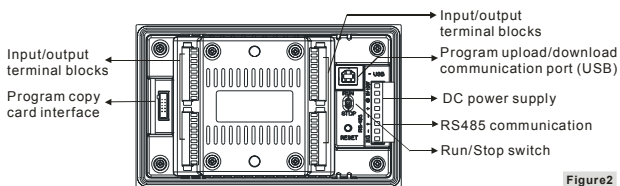

• **Front View and Right Side View (Units: mm, []: inch)**

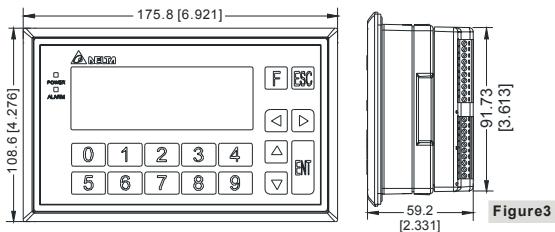

• **Mounting Dimensions (Units: mm, []: inch)**

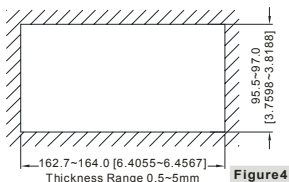

• **Top View (Units: mm, []: inch)**

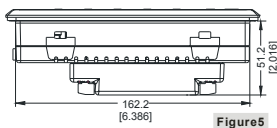

■ Function Specifications

Spec.	Model	TP04P series
PLC program capacity		8k steps
Screen type/Display color		STN-LCD/Monochromatic
Driver		Delta automation products
Function/Numeric keys		0~9, ESC, F, Enter and Up/Down/Left/Right keys
Alarm LED indicator (Red)		Power indication (Blinking for three times)/Communication error alarm/User program indication
Backlight		Automatically turning off the backlight: 1~99 minutes (0: The backlight is not turned off.) (The life span of the backlight is about 50,000 hours at a temperature of 25°C)
Contrast adjustment		Set by software, 10 levels of adjustment
Language/Font		ASCII: (Code page 850) Alphanumeric code (including European characters) Taiwan: Traditional Chinese fonts China: Simplified Chinese fonts
Resolution		192 × 64 dots
Display range		101.8 mm (W) × 35.24 mm (H); 4.1" (diagonal)
Font size		ASCII: 5 × 8, 8 × 8, 8 × 12, 8 × 16
Display text		5×8 dots: 38 characters × 8 rows 8×12 dots: 24 characters × 5 rows 8×8 dots: 24 characters × 8 rows 8×16 dots: 24 characters × 4 rows
Program upload/download communication port USB (COM1)		Transmission method: Virtual communication port Data length: 7 or 8 bits, Stop bits: 1 or 2 bits, Parity: None/Odd/Even Baud rate: 9,600 bps~115,200 bps USB: USB (Type B) terminal
Extension communication port RS485 (COM2) RS485 (COM3)		Asynchronous transmission method: RS-485 Data length: 7 or 8 bits, Stop bits: 1 or 2 bits, Parity: None/Odd/Even Baud rate: 9,600 bps~115,200 bps RS-485: 8 PIN-removable terminal block
Download & Monitoring method		Download program to TP through virtual COM port
Extension interface		Slot for a program copy card

Spec.	Model	TP04P series
Panel component	Explanation	
Alarm LED indicator (Red)	Status 1: When power is ON, LED will start to blink slowly Status 2: When the user-defined conditions are met, LED will blink for one second repeatedly along with an alarm sound.	
Power LED indicator (Green)	When the power is connected to the product, LED will be ON.	
Display area	LCM display area. It is used to display current program status.	
Numeric keys	0~9: They function as constants. Users can also define the keys by themselves.	
Function keys	Users can define the keys by themselves	
Enter key	If the input value is correct, users can press the key. Users can define the key in the user page.	
Up/Down/Left/Right keys	Up: increase the value or move up one page. Down: decrease the value or move down one page. Left: Left direction key. Can be used to select the position of the value. Right: Right direction key. Can be used to select the position of the value.	

■ Electrical Specifications

Spec.	Model	TP04P-16TP1R	TP04P-32TP1R	TP04P-22XA1R	TP04P-21EX1R
CPU	LPC1787FBD208				
Program memory	1 MB-flash memory				
RAM of the system	64K Bytes				
Power supply voltage	24VDC (-15% ~ 20%) (With counter-connection protection on the polarity of DC input power)				
Power consumption	3.2W	5.2W	4.2W	4.2W	
Power protection	With counter-connection protection on the polarity of DC input power				
Insulation resistance	> 5 MΩ (all I/O point-to-ground insulation resistance: 500 VDC)				
Noise immunity	ESD (IEC 61131-2, IEC 61000-4-2): 8KV Air Discharge EFT (IEC 61131-2, IEC 61000-4-4): Power Line: 2KV, Digital I/O: 1KV, Analog & Communication I/O: 1KV Damped-Oscillatory Wave: Power Line: 1KV, Digital I/O: 1KV RS (IEC 61131-2, IEC 61000-4-3): 26MHz~1GHz, 10V/m				
Ground	The diameter of ground cannot be less than the diameter of the power cable. (If several TP04P are used, they should be grounded directly.)				
Operating temperature for hardware	0°C~50°C: Relative humidity: 20%-90% RH (non-condensing)				
Storage temperature for hardware	-20°C~60°C				
Waterproof class of the front panel	IP66/NEMA4				
Vibration/Shock resistance	International standards IEC61131-2, IEC 68-2-6 (TEST Fc)/ IEC61131-2 & IEC 68-2-27 (TEST Ea)				
Weight	420g	444g	432g	432g	
Dimensions	175.8 × 108.6 × 59.2 mm (Width(W) × Height(H) × Deep(D))				
Cooling method	Natural air cooling				

Item	Model	Input terminal	
		24VDC (-15% ~ 20%) single common terminal	
Input number		X0, X1	X2~X7, X10~X17
Input type		DC (Sinking or sourcing)	
Input voltage (±10%)		24VDC, 5mA	
Input impedance		4.7k ohm	
Maximum frequency		10KHz	60Hz
Action level	Off→On	> 16.5 VDC	
	On→Off	< 8 VDC	
Response time	Off→On	<20us	10ms
	On→Off	<50us	

Item	Model	Output terminal	
		Relay	
Voltage specifications		250VAC, < 30VDC	
Current specifications	Resistive	1.5A /1 point (5A/COM)	
	Inductive	#1	
	Bulb	20WDC/100WAC	
Response time Off→On		Approximately 10 ms	

#1: Life curves

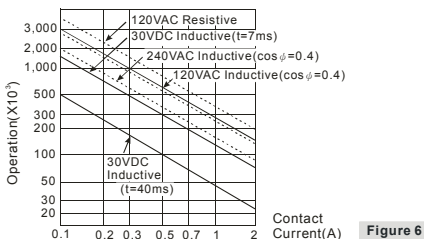

Item	Model	Specifications for the analog input/output of TP04P-22XA1R/TP04P-21EX1R			
		Voltage input*	Current input	Voltage output*	Current output
Analog input range		$\pm 10\text{V}$	22XA1R: $\pm 20\text{mA}$ 21EX1R: 0~20mA	--	--
Analog output range		--	--	$\pm 10\text{V}$	0~20mA
Digital conversion range		± 2000	22XA1R: ± 1000 21EX1R: 0~4000	± 2000	22XA1R: 0~4000 21EX1R: 0~4000
Resolution		12 bits (1LSB=5mV)	22XA1R: 11 bits (1LSB=20uA) 21EX1R: 12 bits (1LSB=5uA)	12 bits (1LSB=5mV)	12 bits (1LSB=5uA)
Input impedance		1M Ω	250 Ω	--	--
Output impedance		--	--	100 Ω	
Overall accuracy		25°C/77°F: The error is $\pm 0.5\%$ of the input within the range 0~55°C/32~131°F: The error is $\pm 1\%$ of the input within the range			
Response time		3ms/Channel			
Isolation		None		--	
Absolute Input range		$\pm 15\text{V}$	22XA1R: $\pm 32\text{mA}$ 21EX1R: 0~32mA	--	--
Digital data format		Two's complement of a 16-bit number 11 bits are significant bits.			
Maximum current output (Load allowed)		--	--	10mA (1K Ω ~2M Ω)	0~500 Ω
Protection		--	--	The voltage output is equipped with a short circuit protection and the overcurrent protection. (If the voltage output is short-circuited for a long time, it may be damaged.) The current output can be an open circuit.	

*: The specifications for voltage output/voltage input is only applicable to TP04P-22XA1R.

Item	Model	TP04P-21EX1R
		Specifications for temperature measurement
Sensor type		2-wire/3-wire PT100
Driving current		1.6mA
Temperature input range		-20°C~160°C

Model	TP04P-21EX1R
Item	Specifications for temperature measurement
Digital conversion range	-200~1600
Resolution	0.1°C
Overall accuracy	0~55°C/32~131°F: The error is $\pm 1\%$ of the input within the range
Response time	300ms×Number of channels
Isolation	None
Digital data format	Two's complement of a 16-bit number

■ I/O Configuration (Figure 7)

TP04P-32TP1R (16DI/16DO)	TP04P-16TP1R (8DI/8DO)	TP04P-22XA1R (8DI/8DO/4AI/2AO)	TP04P-21EX1R (8DI/8DO/2AI/1AO/2PT)																																																																																																																																												
<table border="1"> <tr><td>S/S0</td><td>C0</td></tr><tr><td>X0</td><td>Y0</td></tr><tr><td>X1</td><td>Y1</td></tr><tr><td>X2</td><td>Y2</td></tr><tr><td>X3</td><td>Y3</td></tr><tr><td>X4</td><td>Y4</td></tr><tr><td>X5</td><td>Y5</td></tr><tr><td>X6</td><td>Y6</td></tr><tr><td>X7</td><td>Y7</td></tr><tr><td>•</td><td>•</td></tr><tr><td>S/S1</td><td>C1</td></tr><tr><td>X10</td><td>Y10</td></tr><tr><td>X11</td><td>Y11</td></tr><tr><td>X12</td><td>Y12</td></tr><tr><td>X13</td><td>Y13</td></tr><tr><td>X14</td><td>Y14</td></tr><tr><td>X15</td><td>Y15</td></tr><tr><td>X16</td><td>Y16</td></tr><tr><td>X17</td><td>Y17</td></tr><tr><td>•</td><td>•</td></tr></table>	S/S0	C0	X0	Y0	X1	Y1	X2	Y2	X3	Y3	X4	Y4	X5	Y5	X6	Y6	X7	Y7	•	•	S/S1	C1	X10	Y10	X11	Y11	X12	Y12	X13	Y13	X14	Y14	X15	Y15	X16	Y16	X17	Y17	•	•	<table border="1"> <tr><td>S/S0</td><td>C0</td></tr><tr><td>X0</td><td>Y0</td></tr><tr><td>X1</td><td>Y1</td></tr><tr><td>X2</td><td>Y2</td></tr><tr><td>X3</td><td>Y3</td></tr><tr><td>X4</td><td>Y4</td></tr><tr><td>X5</td><td>Y5</td></tr><tr><td>X6</td><td>Y6</td></tr><tr><td>X7</td><td>Y7</td></tr><tr><td>•</td><td>•</td></tr></table>	S/S0	C0	X0	Y0	X1	Y1	X2	Y2	X3	Y3	X4	Y4	X5	Y5	X6	Y6	X7	Y7	•	•	<table border="1"> <tr><td>S/S0</td><td>C0</td></tr><tr><td>X0</td><td>Y0</td></tr><tr><td>X1</td><td>Y1</td></tr><tr><td>X2</td><td>Y2</td></tr><tr><td>X3</td><td>Y3</td></tr><tr><td>X4</td><td>Y4</td></tr><tr><td>X5</td><td>Y5</td></tr><tr><td>X6</td><td>Y6</td></tr><tr><td>X7</td><td>Y7</td></tr><tr><td>•</td><td>•</td></tr><tr><td>V0+</td><td>V3+</td></tr><tr><td>V0-</td><td>V3-</td></tr><tr><td>I0</td><td>I3</td></tr><tr><td>FE</td><td>FE</td></tr><tr><td>V1</td><td>V4</td></tr><tr><td>I1</td><td>I4</td></tr><tr><td>V2+</td><td>AG</td></tr><tr><td>V2-</td><td>Y8</td></tr><tr><td>I2</td><td>I5</td></tr><tr><td>FE</td><td>AG</td></tr></table>	S/S0	C0	X0	Y0	X1	Y1	X2	Y2	X3	Y3	X4	Y4	X5	Y5	X6	Y6	X7	Y7	•	•	V0+	V3+	V0-	V3-	I0	I3	FE	FE	V1	V4	I1	I4	V2+	AG	V2-	Y8	I2	I5	FE	AG	<table border="1"> <tr><td>S/S0</td><td>C0</td></tr><tr><td>X0</td><td>Y0</td></tr><tr><td>X1</td><td>Y1</td></tr><tr><td>X2</td><td>Y2</td></tr><tr><td>X3</td><td>Y3</td></tr><tr><td>X4</td><td>Y4</td></tr><tr><td>X5</td><td>Y5</td></tr><tr><td>X6</td><td>Y6</td></tr><tr><td>X7</td><td>Y7</td></tr><tr><td>•</td><td>•</td></tr><tr><td>I0+</td><td>L3+</td></tr><tr><td>I0-</td><td>L3-</td></tr><tr><td>FE</td><td>I5</td></tr><tr><td>I1+</td><td>FE</td></tr><tr><td>I1-</td><td>•</td></tr><tr><td>FE</td><td>L4+</td></tr><tr><td>•</td><td>L4-</td></tr><tr><td>I2</td><td>I4-</td></tr><tr><td>AG</td><td>FE</td></tr><tr><td>FE</td><td>•</td></tr></table>	S/S0	C0	X0	Y0	X1	Y1	X2	Y2	X3	Y3	X4	Y4	X5	Y5	X6	Y6	X7	Y7	•	•	I0+	L3+	I0-	L3-	FE	I5	I1+	FE	I1-	•	FE	L4+	•	L4-	I2	I4-	AG	FE	FE	•
S/S0	C0																																																																																																																																														
X0	Y0																																																																																																																																														
X1	Y1																																																																																																																																														
X2	Y2																																																																																																																																														
X3	Y3																																																																																																																																														
X4	Y4																																																																																																																																														
X5	Y5																																																																																																																																														
X6	Y6																																																																																																																																														
X7	Y7																																																																																																																																														
•	•																																																																																																																																														
S/S1	C1																																																																																																																																														
X10	Y10																																																																																																																																														
X11	Y11																																																																																																																																														
X12	Y12																																																																																																																																														
X13	Y13																																																																																																																																														
X14	Y14																																																																																																																																														
X15	Y15																																																																																																																																														
X16	Y16																																																																																																																																														
X17	Y17																																																																																																																																														
•	•																																																																																																																																														
S/S0	C0																																																																																																																																														
X0	Y0																																																																																																																																														
X1	Y1																																																																																																																																														
X2	Y2																																																																																																																																														
X3	Y3																																																																																																																																														
X4	Y4																																																																																																																																														
X5	Y5																																																																																																																																														
X6	Y6																																																																																																																																														
X7	Y7																																																																																																																																														
•	•																																																																																																																																														
S/S0	C0																																																																																																																																														
X0	Y0																																																																																																																																														
X1	Y1																																																																																																																																														
X2	Y2																																																																																																																																														
X3	Y3																																																																																																																																														
X4	Y4																																																																																																																																														
X5	Y5																																																																																																																																														
X6	Y6																																																																																																																																														
X7	Y7																																																																																																																																														
•	•																																																																																																																																														
V0+	V3+																																																																																																																																														
V0-	V3-																																																																																																																																														
I0	I3																																																																																																																																														
FE	FE																																																																																																																																														
V1	V4																																																																																																																																														
I1	I4																																																																																																																																														
V2+	AG																																																																																																																																														
V2-	Y8																																																																																																																																														
I2	I5																																																																																																																																														
FE	AG																																																																																																																																														
S/S0	C0																																																																																																																																														
X0	Y0																																																																																																																																														
X1	Y1																																																																																																																																														
X2	Y2																																																																																																																																														
X3	Y3																																																																																																																																														
X4	Y4																																																																																																																																														
X5	Y5																																																																																																																																														
X6	Y6																																																																																																																																														
X7	Y7																																																																																																																																														
•	•																																																																																																																																														
I0+	L3+																																																																																																																																														
I0-	L3-																																																																																																																																														
FE	I5																																																																																																																																														
I1+	FE																																																																																																																																														
I1-	•																																																																																																																																														
FE	L4+																																																																																																																																														
•	L4-																																																																																																																																														
I2	I4-																																																																																																																																														
AG	FE																																																																																																																																														
FE	•																																																																																																																																														

■ Installation

Insert TP04P into the opening hole on the panel, and then tighten the screws. If it needs to be mounted firmly, please use the mounting fixed supports and screws in the accessory package which is packed with TP04P. Insert the hooks of the fixed supports into the fixing holes on the back, and then tighten the screws. Please refer to figure 8 and figure 9 below for more information.

(Δ) The torque exerted on a screw should be 4.75 (kg-cm). Please tighten the screws according to the specifications, otherwise the product may be damaged. If the fixed supports are not installed well, Delta will not guarantee the waterproof rating.) The cover of the mounting panel should be waterproof/dust proof or meet the related specifications (IP66/NEMA4).

Do not install TP04P in the following environment.



- A location full of Airborne dust, metallic particles, oily smoke, corrosive or flammable gases and liquids
- High-temperature and humid environment
- A location in which the product may be shocked and vibrated directly

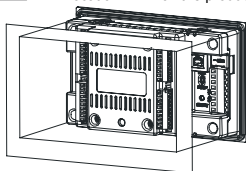

Figure 8

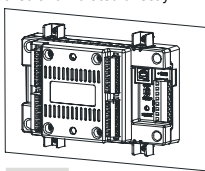
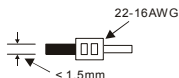

Figure 9

■ Wiring

1. Please use single-core cables or twin-core cables. The diameters of the cables used should be within the range between 16 AWG and 22 AWG (1.5mm). The torque applied to the screw terminals should be 1.90 kg-cm (1.65 in-lbs). Please use copper conducting wires. The temperature of the copper conducting wires should be 60/75°C.



2. DO NOT wire the empty terminal. DO NOT put the input signal cables and the output signal cables in the same wiring.
3. DO NOT drop any tiny metallic conductor into TP04P while you are tightening screw and wiring TP04P. After the wiring is complete, you have to ensure that heat can radiate from TP04P.

◆ Power Supply

The power input of TP04P is DC. When you operates TP04P, please note the following points:

1. The power is connected to two terminals, 24 VDC and 0 V, and the range of power is 20.4 to 28.8 VDC. If the power voltage is less than 20.4VDC, TP04P will stop running, all outputs will be Off, and the ERROR indicator will start to blink.
2. If a power failure lasts for less than 10 ms, the operation of TP04P will not stop. However, if a power failure lasts for long, or the power voltage decreases, TP04P will stop running, and all outputs will be off. After the power returns to the normal status, TP04P will automatically resume the operation. (Users have to note that TP04P is equipped with latched auxiliary relays and registers when they write a program.)

◆ Safety Wiring

Since TP04P is only compatible with DC power supply, Delta's power supply modules (DVPPS01/DVPPS02/DVPPS05) are suitable for it. It is suggested that you should install a protection circuit at the power supply terminal to protect DVPPS01, DVPPS02, or DVPPS05. See the figure below.

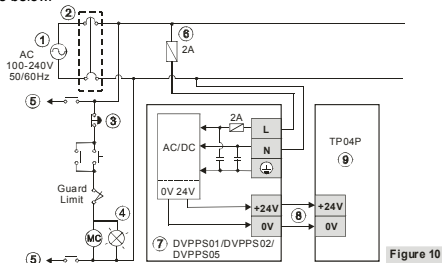

Figure 10

- | | |
|--|---------------------------|
| ① AC power supply: 100 ~ 240VAC, 50/60Hz | ② Breaker |
| ③ Emergency stop: The emergency stop button can be used to cut off the power when an emergency occurs. | |
| ④ Power indicator | ⑤ AC power supply load |
| ⑥ Power supply circuit protection fuse (2A) | ⑦ DVPPS01/DVPPS02/DVPPS05 |
| ⑧ DC power supply output: 24VDC, 500mA | ⑨ TP04P |

◆ Wiring Input Terminals

There are 2 types of DC inputs. They are sinking inputs and sourcing inputs. (See the figures below.)

● Sinking mode

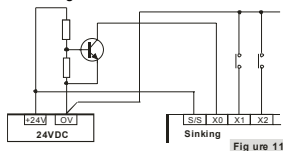

Figure 11

● Sourcing mode

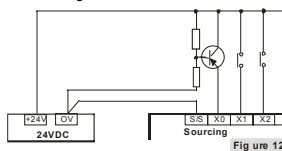

Figure 12

◆ Wiring Relay Output Terminals

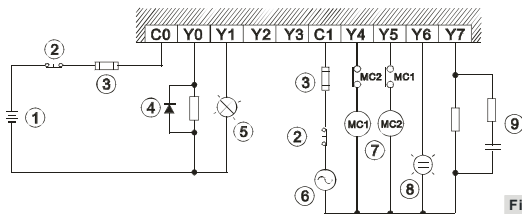
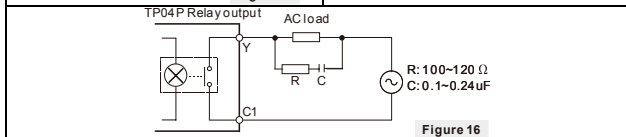
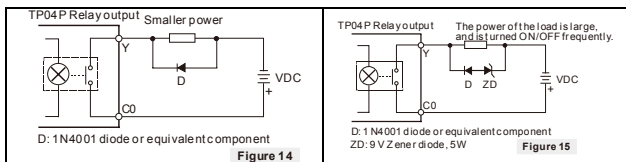

Figure 13



- ① DC power supply
- ② Emergency stop: An external switch is used.
- ③ Fuse: To protect an output circuit, a fuse having a breaking capacity in the range of 5 A to 10 A is connected to a common terminal.
- ④ Transient voltage suppression diode: It can be used to lengthen the lifespan that a contact has.
 1. A Diode is used to suppress the DC passing a load when the power of the load is small. (See figure 14.)
 2. A Diode and a Zener diode are used to suppress the DC passing a load when the power of the load is large, and is turned ON/OFF frequently. (See figure 15.)
- ⑤ Incandescent lamp (resistive load)
- ⑥ AC power supply
- ⑦ Mutually exclusive output: For example, Y4 controls the clockwise rotation of a motor, and Y5 controls the counterclockwise rotation of the motor. The interlock circuit which is formed, and the program in the TP04P series text panel ensure that there are protective measures if an abnormal condition occurs.
- ⑧ Indicator: Neon lamp
- ⑨ Surge absorber: It can be used to reduce the noise produced by an AC load. (See figure 16.)

◆ Wiring Analog Input Terminals

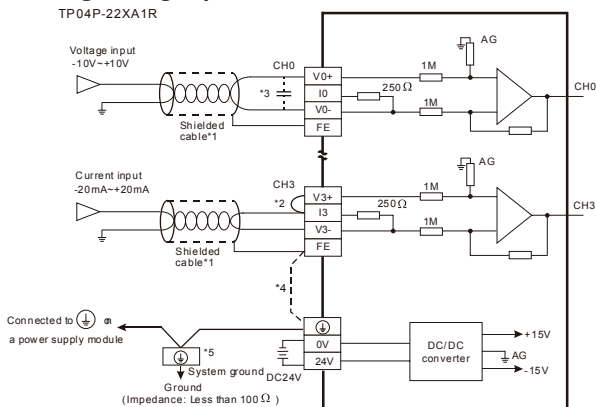

Figure 17

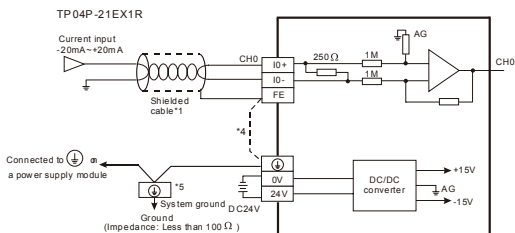

Figure 18

- *1: Please isolate the analog input signal cables from other power cables.
- *2: If the text panel is connected to a current signal, the terminals V3+ and I3+ must be short-circuited.
- *3: If the ripple in the input voltage results in the noise interference with the wiring, please connect the text panel to the capacitor having a capacitance in the range of 0.1 μF to 0.47 μF with a working voltage of 25 V.
- *4: If there is much noise, please connect the terminal FE to the ground terminal.
- *5: Please connect the ground terminal on a power supply module and the analog input terminal FE to the system ground, and then ground the system ground or connect the system ground to a distribution box.

◆ Wiring of Analog Output Terminals

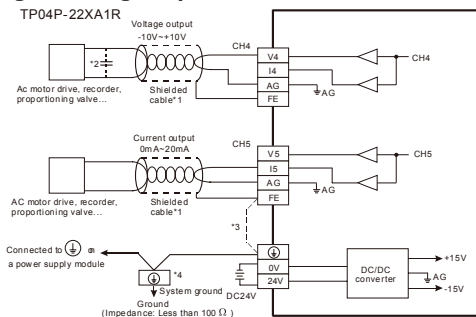

Figure 19

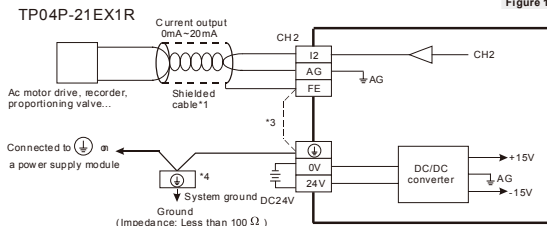

Figure 20

- *1: Please isolate the analog output signal cables from other power cables.
- *2: If a ripple is large for the input terminal of the load and results in the noise interference with the wiring, please connect the module to the capacitor having a capacitance in the range of 0.1 μF to 0.47 μF with a working voltage of 25 V.
- *3: If there is much noise, please connect the terminal FE to the ground terminal.
- *4: Please connect the ground terminal on a power supply module and the analog output terminal FE to the system ground, and then ground the system ground or connect the system ground to a distribution box.

◆ Wiring Temperature Sensors

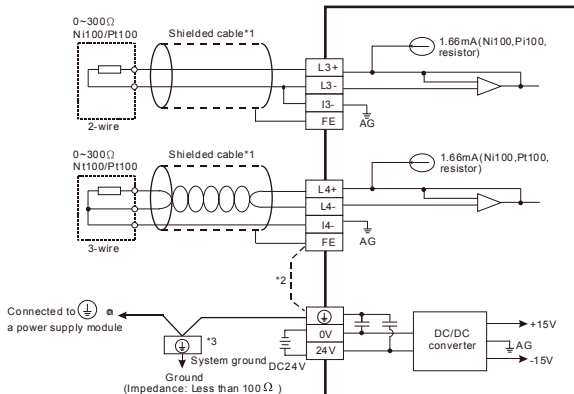

Figure 21

*1: The cables connected to the input terminals should be the cables or the shielded twisted pair cables which can be connected to the temperature sensors, and should be kept separate from other power cables and cables which generate noise.

*2: If there is much noise, please connect the terminal FE to the ground terminal.

*3: Please connect the ground terminal on a power supply module and the analog input terminal FE to the system ground, and then ground the system ground or connect the system ground to a distribution box.

Note: Please do not wire the terminal NC.

◆ RS-485 Wiring

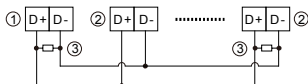

Figure 22

① Master station

② Slave station

③ Terminal resistor

Note: 1. The terminal resistor should be connected to the master station and the last slave station. The resistance of the terminal resistor should be 120Ω.

2. To ensure communication quality, it is suggested that users should use double shielded twisted pair cables (20AWG) for wiring.

■ Communication Connection

TP04P may connect to a PC by using USB adaptor cable.

Please use an AM/BM USB adaptor cable.



Figure 23

■ Battery's Life

Temperature (°C)	-20	0	20	60
Life (Year)	2.0	2.5	2.7	2.8

■ Precision of the Real Time Clock (Second/Month)

Temperature (°C/°F)	0/32	25/77	55/131
Maximum error (Second)	-117	52	-132

感謝您採用台達文本顯示器系列產品。TP04P 結合 PLC 與文本顯示器一體，具有豐富的指令集及 8k steps 的程式記憶體。TP04P 分別支援 PLC 編輯軟體 (WPLSoft 及 ISPSOft) 與 TP 編輯軟體 (TPEditor)，可共用同一個下載埠；TPEditor 軟體規劃部份提供多種物件圖形供使用者選用。使用者可另購程式擴充卡 TP-PCC01，快速移植程式，節省程式下載時間。請搭配台達 DVPPS01、DVPPS02 及 DVPPS05 (電源模組) 一起使用。

- ✓ 請在使用之前，詳細閱讀本使用說明書。本安裝說明書提供給使用者電氣規格、功能規格、安裝配線之相關注意事項。其他詳細之程式設計及指令說明請見 DVP-ES2/EX2/SS2/SA2/SX2/SE&TP 操作手冊【程式篇】，選購之周邊裝置詳細說明請見該產品隨機安裝說明書。
- ✓ 於實施配線前，請務必關閉電源。請勿在上電時觸摸任何端子。輸入電源切斷後，一分鐘之內，請勿觸摸內部電路。請勿在上電時觸摸任何端子。
- ✓ 交流輸入電源不可連接於輸入出信號端，否則可能造成嚴重損壞，請在上電之前再次確認電源配線。
- ✓ 本體上之接地端子  務必正確的接地，可提高產品抗雜訊能力。
- ✓ 本機顯示操作面板防水，但對油污或具腐蝕性之液體不具防護作用，避免以尖銳之物品刮傷面板使用時請注意。
- ✓ 利用原廠包裝附件之固定架，鎖緊面板固定螺絲時，請勿太緊以免造成機殼損壞。

■ 產品外觀尺寸與部位介紹

- 正面圖 (詳細正面圖請參閱英文版之Figure1)
- 背面圖 (詳細背面圖請參閱英文版之Figure2)
- 正面及右側尺寸圖 (單位：公厘·[]：英吋) (詳細尺寸圖請參閱英文版之Figure3)
- 嵌入開孔尺寸 (單位：公厘·[]：英吋) (詳細尺寸圖請參閱英文版之Figure4)
- 俯視圖 (單位：公厘·[]：英吋) (詳細尺寸圖請參閱英文版之Figure5)

■ 功能規格

規格	機型 TP04P 系列	
PLC程式容量	8k steps	
螢幕/色彩	STN-LCD / 單色	
驅動器	台達產品	
功能鍵 / 數字鍵	0 ~ 9 · ESC · F · Enter及上 / 下 / 左 / 右鍵	
警示指示燈 (紅燈)	電源啟動指示 (亮 / 滅三次) / 通訊不通警示 / 使用者程式指定	
背光型式	背光自動關閉設定範圍1 ~ 99分鐘 (設定值0為不關閉) (在常溫25°C下壽命約5萬小時)	
對比調整	軟體設定 · 10段明暗調整	
語言字型	ASCII : (頁碼850) 文字 (包含歐洲字型、繁體字型及簡體字型)	
解析度	192 × 64 點	
顯示範圍	(寬) × (高) = 101.8 × 35.24 (單位：公厘) ; 4.1吋 (對角線)	
字型大小	ASCII : 5 × 8 · 8 × 8 · 8 × 12 · 8 × 16	
顯示的文字數	5×8 畫素字型：38 個字 × 8 列 8×8 畫素字型：24 個字 × 8 列	8×12 畫素字型：24 個字 × 5 列 8×16 畫素字型：24 個字 × 4 列
程式上下載通訊埠 USB (COM1)	傳送方式：虛擬通訊埠 資料長度：7或8 bits · 停止位元：1或2 bits · 極性：無 / 奇 / 偶 傳送速度：9,600bps ~ 115,200bps USB：USB (Type B) 端子	
擴充通訊埠 RS485 (COM2) RS485 (COM3)	非同步傳送方式：RS-485 資料長度：7或8 bits · 停止位元：1或2 bits · 極性：無 / 奇 / 偶 傳送速度：9,600bps ~ 115,200bps RS-485：8 PIN 脫落式端子	

規格	機型	TP04P 系列
下載與監控方式		通過虛擬通訊埠下載至TP
擴充介面		程式複製卡插槽
面板元件		說明
警示指示燈 (紅燈)		狀態一：當啟動電源時，指示燈慢慢開始閃爍。 狀態二：當符合使用者設定條件時，指示燈會重覆持續亮一秒並發出警報聲。
電源指示燈 (綠燈)		電源開啟時燈亮
顯示區		液晶顯示模組，顯示目前程式狀態。
數字鍵		0~9：可作為常數輸入鍵，也可由使用者定義其個別功能鍵。
F鍵		可供使用者定義
輸入鍵 (ENT)		當輸入值確認正確無誤時，即可按下此鍵；在使用者頁面時可由使用者重新定義功能。
命令操作鍵		上：此鍵為向上方向鍵，可作為數值遞增輸入或換至上頁等操作。 下：此鍵為向下方向鍵，可作為數值遞減輸入或換至下頁等操作。 左：此鍵為左方向鍵，可作為選擇數值位置操作。 右：此鍵為右方向鍵，可作為選擇數值位置操作。 在使用者頁面時，可由使用者重新定義其個別功能。

■ 電氣規格

項目	機型	TP04P-16TP1R	TP04P-32TP1R	TP04P-22XA1R	TP04P-21EX1R
中央處理單元 (CPU)		LPC1787FBD208			
程式記憶體容量		1MB 快閃記憶體			
系統RAM		64K Byte			
電源電壓		24VDC (-15% ~ 20%) (具直流輸入電源極性反接保護)			
消耗電力		3.2W	5W	4.2W	4.2W
電源保護		具直流輸入電源極性反接保護			
絕緣阻抗		> 5MΩ (所有輸出 / 入點對地之間500VDC)			
雜訊免疫力		ESD (IEC 61131-2, IEC 61000-4-2): 8KV Air Discharge EFT (IEC 61131-2, IEC 61000-4-4): Power Line: 2KV, Digital I/O: 1KV, Analog & Communication I/O: 1KV Damped-Oscillatory Wave: Power Line: 1KV, Digital I/O: 1KV RS (IEC 61131-2, IEC 61000-4-3): 26MHz ~ 1GHz, 10V/m			
接地		接地配線之線徑不得小於電源端配線線徑 (多台TP04P同時使用時，請務必單點接地)			
硬體使用溫度		0°C ~ 50°C；相對濕度20% - 90% RH (不可凝結)			
硬體儲藏溫度		-20°C ~ 60°C			
前面板防水等級		IP66 / NEMA4			
耐震動/衝擊		國際標準規範 IEC61131-2, IEC 68-2-6 (TEST Fc) / IEC61131-2 & IEC 68-2-27 (TEST Ea)			
重量		420g	444g	432g	432g
外型尺寸		175.8 × 108.6 × 59.2 mm (寬 (W) × 高 (H) × 厚 (D))			
冷卻方式		空氣對流自然冷卻			
	機種	輸入點電氣規格			
項目		24VDC (-15% ~ 20%) 單端共點輸入			
輸入點		X0, X1		X2~X7, X10~X17	

輸入接線型式	由端子 S/S 變換接線為 SINK 或 SOURCE		
輸入信號電壓(±10%)	24VDC, 5mA		
輸入點阻抗	4.7k Ohm		
最大輸入頻率	10KHz	60Hz	
動作位準	Off→On	> 16.5 VDC	
	On→Off	< 8 VDC	
反應時間	Off→On	<20us	10ms
	On→Off	<50us	
項目	機種	輸出點電氣規格	
		繼電器	
電壓規格	250VAC, < 30VDC		
電流規格	電阻性	1.5A/1 點 (5A/COM)	
	電感性	#1	
	燈泡	20WDC/100WAC	
反應時間	Off→On	約 10ms	
	On→Off		

#1：生命週期曲線請參閱英文版之 Figure6。

項目	機種	TP04P-22XA1R/TP04P-21EX1R 類比規格			
		電壓輸入*	電流輸入	電壓輸出*	電流輸出
類比輸入範圍	±10V	22XA1R: ±20mA 21EX1R: 0~20mA	--	--	
類比輸出範圍	--	--	±10V	0~20mA	
數位轉換範圍	±2000	22XA1R: ±1000 21EX1R: 0~4000	±2000	22XA1R: 0~4000 21EX1R: 0~4000	
解析度	12 bits (1LSB=5mV)	22XA1R: 11 bits (1LSB=20uA) 21EX1R: 12 bits (1LSB=5uA)	12 bits (1LSB=5mV)	12 bits (1LSB=5uA)	
輸入阻抗	1MΩ	250Ω	--	--	
輸出阻抗	--	--	100Ω		
總和精密度	±0.5%在 25°C (77°F) 範圍內滿刻度時； ±1%在 0~55°C (32~131°F) 範圍內滿刻度時。				
響應時間	3ms/通道				
隔離方式	無隔離		--		
絕對輸入範圍	±15V	22XA1R: ±32mA 21EX1R: 0~32mA	--	--	
數位資料格式	16 位元二補數，有效位 11 bits				
最大輸出電流 (容許負載)	--	--	10mA (1KΩ~2MΩ)	0~500Ω	
保護	--	--	電壓輸出具短路保護 (請勿長時間短路，有燒毀可能) 電流輸出可開路		

*: 電壓輸出/電壓輸入規格只適用於機種 TP04P-22XA1R

項目	機種	TP04P-21EX1R
		溫度量測規格
感應器型式		2 線/3 線 PT100
驅動電流		1.6mA
輸入溫度範圍		-20°C~160°C
數位轉換範圍		-200~1600
解析度		0.1°C
總和精密度		±1% 在 0~55°C (32~131°F) 範圍內滿刻度時

機種	TP04P-21EX1R
項目	溫度量測規格
響應時間	300ms×通道
隔離方式	未隔離
數位資料格式	16 位元二補數

■ 輸入/輸出配置 (請參閱英文版之 Figure7)

■ 安裝方式

TP04P 安裝於控制盤時，請直接將 TP 由盤面的正面直接放入即可 (嵌入式)。若要固定更牢固，可使用原廠包裝中所附的固定架含螺絲，直接嵌入後蓋四端凹槽處固定，並將螺絲平均鎖緊即可 (△固定螺絲時請以扭力：4.75 (kg-cm) 鎖緊，請勿超過此範圍以免破壞面板；如未正確使用固定架，台達不保證防水等級。)，詳細圖面請參閱英文版 Figure8 與 Figure9。該安裝的配電盤外殼必須符合防水防塵或符合相等規格 (IP66 / NEMA4) 的測試條件。



TP04P 裝置於以下環境中：

- ▶ 落塵大、油煙、金屬性粉塵、腐蝕性或可燃性氣體
- ▶ 高溫、結露
- ▶ 直接震動、衝擊

■ 配線端子

1. 輸出/入配線端請使用 22-16AWG (1.5mm) 單芯裸線或
多芯線端子規格如右圖所示。TP04P 端子螺絲扭力為 1.90
kg-cm (1.65 in-lbs)。只能使用 60/75°C 的銅導線。

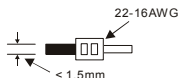

2. 空端子請勿配線。輸入點信號線與輸出點等動力線請勿置於同一線槽內。
3. 鎖螺絲及配線時請避免微小的金屬導體掉入 TP04P 內部，並在配線完成後保持散熱空間。

◆ 電源端

TP04P 機種為直流電源輸入，在使用上應注意下列事項：

1. 電源請接於 24VDC 及 0V 兩端，電源範圍為 20.4 ~ 28.8VDC，當電源電壓低於 20.4VDC 時，TP04P 會停止運轉，輸出全部 Off，ERROR LED 快速閃爍。
2. 當停電時間低於 10ms 時，TP04P 不受影響繼續運轉，當停電時間過長或電源電壓下降將使 TP04P 停止運轉，輸出全部 Off，當電源恢復正常時，TP04P 亦自動回復運轉。(TP04P 內部具停電保持的輔助繼電器及暫存器，使用者在規劃程式設計時應特別注意使用。)

◆ 安全配線回路

由於 TP04P 的電源為 DC Only 的機種，因此可搭配台達之電源供應模組 (DVPPS01/DVPPS02/DVPPS05) 提供電源給 TP04P。為保護 DVPPS01/DVPPS02/DVPPS05，建議可在電源的輸入回路端配置如下的保護回路，配置圖請參閱英文版之 Figure 10 所示。

- | | |
|---|------------------------------|
| ① 交流電源供應：100 ~ 240VAC, 50/60Hz | ② 斷路器 |
| ③ 緊急停止：為預防突發狀況發生，設置緊急停止按鈕，可在狀況發生時，切斷系統電源。 | |
| ④ 電源指示燈 | ⑤ 交流電源負載 |
| ⑥ 電源回路保護用保險絲 (2A) | ⑦ DVPPS01/DVPPS02/DVPPS05 本體 |
| ⑧ 直流電源供應輸出：24VDC，500mA | ⑨ TP04P 本體 |

◆ 輸入點之配線

輸入點之入力信號為直流電源 DC 輸入型式，共有兩種接法：SINK 及 SOURCE，其定義與輸入點回路等效電路配線圖，請參閱英文版之 Figure 11 及 Figure 12。

◆ 繼電器輸出回路配線

詳細配線圖請參閱英文版之 Figure13。

- | | |
|---|---------------|
| ① 直流電源供給 | ② 緊急停止：使用外部開關 |
| ③ 保險絲：使用 5 ~ 10A 的保險絲容量於輸出接點的共用點，保護輸出點回路。 | |
| ④ 突波吸收二極體：可增加接點壽命。 | |
| 1. DC 負載電源之二極體抑制：功率較小時使用 (請參閱英文版之 Figure 14) | |
| 2. DC 負載電源之二極體+Zener 抑制：大功率且 On/Off 頻繁時使用 (請參閱英文版之 Figure 15) | |

⑤ 白熾燈 (電阻性負載)

⑥ 交流電源供給

⑦ 互斥輸出：例如，將 Y4 與 Y5 用以控制對應馬達的正轉及反轉，使外部電路形成互鎖，配合 TP04P 內部程式，確保任何異常突發狀況發生時，均有安全的保護措施。

⑧ 指示燈：氖燈

⑨ 突波吸收器：可減少交流負載上的雜訊 (請參閱英文版之 Figure 16)

◆ 類比輸入外部配線 (請參閱英文版之 Figure 17 及 Figure 18)

註 1：類比輸入請與其他電源隔離

註 2：如果連接電流訊號時，V3+與 I3+端子請務必短路。

註 3：如果輸入電壓有漣波造成配線受雜訊干擾時，請連接 0.1~0.47uF 25V 之電容。

註 4：如果雜訊過大，請將 FE 及接地端子連接。

註 5：請將電源模組的接地端子及類比輸入端之 FE 連接到系統接地點，再將系統接地點作第三種接地或接到配電箱之機殼上。

◆ 類比輸出外部配線 (請參閱英文版之 Figure 19 及 Figure 20)

註 1：類比輸出請與其他電源隔離

註 2：如果負載之輸入端漣波太大造成配線受雜訊干擾時，請連接 0.1~0.47uF 25V 之電容

註 3：如果雜訊過大，請將 FE 及接地端子連接。

註 4：請將電源模組的接地端子及類比輸出端之 FE 連接到系統接地點，再將系統接地點作第三種接地或接到配電箱之機殼上。

◆ 溫度量測外部配線 (請參閱英文版之 Figure 21)

註 1：使用於類比輸入的配線應採用溫度感測器之連接線或雙絞隔離線，且應與其他電源或可能引起雜訊之接線分開。

註 2：如果雜訊過大，請將 FE 及接地端子連接。

註 3：請將電源模組的接地端子及溫度感測信號輸入端之 FE 連接到系統接地點，再將系統接地點作第三種接地或接到配電箱之機殼上。

注意：空端子請勿配線。

◆ RS-485 建議接線

詳細接線圖請參閱英文版之 Figure 22。

① 主站

② 從站

③ 終端電阻

附註：1. 終端電阻建議連接於主站及最後一台從站上，且其電阻值建議為 120Ω。

2. 為確保連線品質，線材建議使用具有雙層遮蔽線之通訊雙絞線 (20AWG)。

■ 通訊連接線配線圖

- TP04P程式規劃 - 使用USB

請使用 USB A 公轉 B 公之連接電纜線，詳細圖面請參閱英文版之 Figure 23。

■ 電池壽命

溫度 (°C)	-20	0	20	60
壽命 (年)	2.0	2.5	2.7	2.8

■ 萬年曆的精度 (秒 / 月)

溫度 (°C/°F)	0/32	25/77	55/131
最大誤差 (秒)	-117	52	-132

感谢您采用台达文本显示器系列产品。TP04P 结合 PLC 与文本显示器一体，具有丰富的指令集及 8k steps 的程序内存。TP04P 分别支持 PLC 编辑软件 (WPLSoft 及 ISPSOft) 与 TP 编辑软件 (TPEditor)。可共享同一个下载埠；TPEditor 软件规划部份提供多种对象图形供使用者选用。使用者可另购程序扩充卡 TP-PCC01，快速移植程序，节省程序下载时间。请搭配台达 DVPPS01、DVPPS02 及 DVPPS05 (电源模块) 一起使用。

- ✚ 请在使用之前，详细阅读本使用说明书。本安装说明书提供给使用者电气规格、功能规格、安装配线之相关注意事项。其它详细之程序设计及指令说明请见 DVP-ES2/EX2/SS2/SA2/SX2/SE&TP 操作手册【程序篇】。选购之周边装置详细说明请见该产品随机安装说明书。
- ✚ 请在使用之前，详细阅读本使用说明书。于实施配线前，请务必关闭电源。请勿在上电时触摸任何端子。输入电源切断后，一分钟之内，请勿触摸内部电路。请勿在上电时触摸任何端子。
- ✚ 交流输入电源不可连接于输入/出信号端，否则可能造成严重损坏，请在上电之前再次确认电源配线。
- ✚ 本体上之接地端子  务必正确的接地，可提高产品抗噪声能力。
- ✚ 本机显示操作面板防水，但对油污或具腐蚀性之液体不具防护作用，避免以尖锐之物品刮伤面板使用时请注意。
- ✚ 利用原厂包装附件之固定架，锁紧面板固定螺丝时，请勿太紧以免造成机壳损坏。

■ 产品外观尺寸与部位介绍

- 正面图 (详细正面图请参阅英文版之Figure1)
- 背面图 (详细背面图请参阅英文版之Figure2)
- 正面图及右侧图 (单位: 公厘, []: 英吋) (详细尺寸图请参阅英文版之Figure3)
- 嵌入开孔尺寸 (单位: 公厘, []: 英吋) (详细尺寸图请参阅英文版之Figure4)
- 俯视图 (单位: 公厘, []: 英吋) (详细尺寸图请参阅英文版之Figure5)

■ 功能规格

规格 \ 机型	TP04P 系列	
PLC程序容量	8k steps	
屏幕/色彩	STN-LCD / 单色	
驱动器	台达产品	
功能键 / 数字键	0 ~ 9 · ESC · F · Enter及上 / 下 / 左 / 右键	
警示指示灯 (红灯)	电源启动指示 (亮 / 灭三次) / 通讯不通警示 / 使用者程序指定	
背光型式	背光自动关闭设定范围1 ~ 99分钟 (设定值0为不关闭) (在常温25°C下寿命约5万小时)	
对比调整	软件设定 · 10段明暗调整	
语言字型	ASCII : (页码850) 文字 (包含欧洲字型、繁体字型及简体字型)	
分辨率	192 × 64 点	
显示范围	(宽) × (高) = 101.8 × 35.24 (单位: 毫米); 4.1吋 (对角线)	
字号	ASCII : 5 × 8 · 8 × 8 · 8 × 12 · 8 × 16	
显示的文字数	5×8 画素字型: 38 个字 × 8 列 8×8 画素字型: 24 个字 × 8 列	8×12 画素字型: 24 个字 × 5 列 8×16 画素字型: 24 个字 × 4 列
程序上下载通讯端口 USB (COM1)	传送方式: 虚拟通讯端口 数据长度: 7或8 bits · 停止位: 1或2 bits · 极性: 无 / 奇 / 偶 传送速度: 9,600bps ~ 115,200bps USB: USB (Type B) 端子	
扩充通讯端口 RS485 (COM2) RS485 (COM3)	异步传送方式: RS-485 数据长度: 7或8 bits · 停止位: 1或2 bits · 极性: 无 / 奇 / 偶 传送速度: 9,600bps ~ 115,200bps	

规格	机型	TP04P 系列
		RS-485 : 8 PIN 脱落式端子
下载与监控方式		通过虚拟通讯端口下载至TP
扩充接口		程序复制卡插槽
面板组件		说明
警示指示灯 (红灯)		状态一 : 当启动电源时 , 指示灯慢慢开始闪烁。
警示指示灯 (红灯)		状态二 : 当符合使用者设定条件时 , 指示灯会重复持续亮一秒并发出警
电源指示灯 (绿灯)		电源开启时灯亮
显示区		液晶显示模块 , 显示目前程序状态。
数字键		0~9 : 可作为常数输入键 , 也可由使用者定义其个别功能键。
F键		可供使用者定义
输入键 (ENT)		当输入值确认正确无误时 , 即可按下此键 ; 在使用者页面时可由使用者重新定义功能。
命令操作键		上 : 此键为向上方向键 , 可作为数值递增输入或换至上页等操作。 下 : 此键为向下方向键 , 可作为数值递减输入或换至下页等操作。 左 : 此键为左方向键 , 可作为选择数值位置操作。 右 : 此键为右方向键 , 可作为选择数值位置操作。 在使用者页面时 , 可由使用者重新定义其个别功能。

■ 电气规格

项目	机型	TP04P-16TP1R	TP04P-32TP1R	TP04P- 22XA1R	TP04P- 21EX1R
中央处理单元 (CPU)		LPC1787FBD208			
程序内存容量		1MB 闪存			
系统RAM		64K Byte			
电源电压		24VDC (-15% ~ 20%) (具直流输入电源极性反接保护)			
消耗电力		3.2W	5.2W	4.2W	4.2W
电源保护		具直流输入电源极性反接保护			
绝缘阻抗		> 5MΩ (所有输出 / 入点对地之间500VDC)			
噪声免疫力		ESD (IEC 61131-2, IEC 61000-4-2): 8KV Air Discharge EFT (IEC 61131-2, IEC 61000-4-4): Power Line: 2KV, Digital I/O: 1KV, Analog & Communication I/O: 1KV Damped-Oscillatory Wave: Power Line: 1KV, Digital I/O: 1KV RS (IEC 61131-2, IEC 61000-4-3): 26MHz ~ 1GHz, 10V/m			
接地		接地配线之线径不得小于电源端配线线径 (多台TP04P同时使用时 , 请务必单点接地)			
硬件使用温度		0°C ~ 50°C ; 相对湿度20% - 90% RH (不可凝结)			
硬件储藏温度		-20°C ~ 60°C			
前面板防水等级		IP66 / NEMA4			
耐震动/冲击		国际标准规范 IEC61131-2, IEC 68-2-6(TEST Fc)/ IEC61131-2 & IEC 68-2-27 (TEST Ea)			
重量		420g	444g	432g	432g
外型尺寸		175.8 × 108.6 × 59.2 mm (宽 (W) × 高 (H) × 厚 (D))			
冷却方式		空气对流自然冷却			

机种		输入点电气规格	
项目	24VDC (-15% ~ 20%) 单端共点输入		
输入点	X0, X1	X2~X7, X10~X17	
输入接线型式	由端子 S/S 变换接线为 SINK 或 SOURCE		
输入信号电压(±10%)	24VDC, 5mA		
输入点阻抗	4.7k Ohm		
最大输入频率	10KHz	60Hz	
动作位准	Off→On	> 16.5 VDC	
	On→Off	< 8 VDC	
反应时间	Off→On	<20us	10ms
	On→Off	<50us	
机种		输出点电气规格	
项目	继电器		
电压规格	250VAC, < 30VDC		
电流规格	电阻性	1.5A /1 点 (5A/COM)	
	电感性	#1	
	灯泡	20WDC/100WAC	
反应时间	约 10ms		

#1：生命周期曲线请参阅英文版之 Figure 6。

机种		TP04P-22XA1R/TP04P-21EX1R 模拟规格			
项目	电压输入*	电流输入	电压输出*	电流输出	
模拟输入范围	±10V	22XA1R: ±20mA 21EX1R: 0~20mA	--	--	
模拟输出范围	--	--	±10V	0~20mA	
数字转换范围	±2000	22XA1R: ±1000 21EX1R: 0~4000	±2000	22XA1R: 0~4000 21EX1R: 0~4000	
分辨率	12 bits (1LSB=5mV)	22XA1R: 11 bits (1LSB=20uA) 21EX1R: 12 bits (1LSB=5uA)	12 bits (1LSB=5mV)	12 bits (1LSB=5uA)	
输入阻抗	1MΩ	250Ω	--	--	
输出阻抗	--	--	100Ω		
总和精密度	±0.5%在 25°C (77°F) 范围内满刻度时； ±1%在 0~55°C (32~131°F) 范围内满刻度时。				
响应时间	3ms/通道				
隔离方式	无隔离		--		
绝对输入范围	±15V	22XA1R: ±32mA 21EX1R: 0~32mA	--	--	
数字数据格式	16 位二补码，有效位 11 bits				
最大输出电流 (容许负载)	--	--	10mA (1KΩ~2MΩ)	0~500Ω	
保护	--	--	电压输出具短路保护(请勿长时间短路， 有烧毁可能) 电流输出可开路		

*: 电压输出/电压输入规格只适用于机种 TP04P-22XA1R

机种		TP04P-21EX1R
项目	温度量测规格	
感应器型式	2 线/3 线 PT100	
驱动电流	1.6mA	
输入温度范围	-20°C~160°C	

机种	TP04P-21EX1R
项目	温度量测规格
数字转换范围	-200~1600
分辨率	0.1°C
总和精密度	±1% 在 0~55°C (32~131°F) 范围内满刻度时。
响应时间	300ms×通道
隔离方式	未隔离
数字数据格式	16 位二补码

■ 输入/输出配置 (请参阅英文版之 Figure7)

■ 安装方式

TP04P 安装于控制盘时，请直接将 TP 由盘面的正面直接放入即可 (嵌入式)。若要固定更牢固，可使用原厂包装中所附的固定架含螺丝，直接嵌入后盖四端凹槽处固定，并将螺丝平均锁紧即可 (△固定螺丝时请以扭力：4.75 (kg-cm) 锁紧，请勿超过此范围以免破坏面板；如未正确使用固定架，台达不保证防水等级)。详细图画请参阅英文版 Figure8 与 Figure9。该安装的配电盘外壳必须符合防水防尘或符合相等规格 (IP66 / NEMA4) 的测试条件。

请勿将 TP04P 装置于以下环境中：



- ▶ 落尘大、油烟、金属性粉尘、腐蚀性或可燃性气体
- ▶ 高温、结露
- ▶ 直接震动、冲击

■ 配线端子

1. 输出/入配线端请使用 22-16AWG (1.5mm) 单蕊裸线或多蕊线端子规格如右图所示。TP04P 端子螺丝扭力为 1.90 kg-cm (1.65 in-lbs)。只能使用 60/75°C 的铜导线。
2. 空端子请勿配线。输入点信号线与输出点等动力线请勿置于同一线槽内。
3. 锁螺丝及配线时请避免微小的金属导体掉入 TP04P 内部，并在配线完成后保持散热空间。

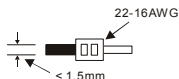

◆ 电源端

TP04P 机种为直流电源输入，在使用上应注意下列事项：

1. 电源请接于 24VDC 及 0V 两端，电源范围为 20.4 ~ 28.8VDC，当电源电压低于 20.4VDC 时，TP04P 会停止运转，输出全部 Off，ERROR LED 快速闪烁。
2. 当停电时间低于 10ms 时，TP04P 不受影响继续运转，当停电时间过长或电源电压下降将使 TP04P 停止运转，输出全部 Off，当电源恢复正常时，TP04P 亦自动回复运转。(TP04P 内部具停电保持的辅助继电器及缓存器，使用者在规划程序设计时应特别注意使用)。

◆ 安全配线回路

由于 TP04P 的电源为 DC Only 的机种，因此可搭配台达之电源供应模块 (DVPPS01/DVPPS02/DVPPS05) 提供电源给 TP04P。为保护 DVPPS01/DVPPS02/DVPPS05，建议可在电源的输入回路端配置如下的保护回路，配置图请参阅英文版之 Figure 10 所示。

① 交流电源供应：100 ~ 240VAC, 50/60Hz	② 断路器
③ 紧急停止：为预防突发状况发生，设置紧急停止按钮，可在状况发生时，切断系统电源。	
④ 电源指示灯	⑤ 交流电源负载
⑥ 电源回路保护用保险丝 (2A)	⑦ DVPPS01/DVPPS02/DVPPS05 本体
⑧ 直流电源供应输出：24VDC，500mA	⑨ TP04P 本体

◆ 输入点之配线

输入点之入力信号为直流电源 DC 输入型式，共有两种接法：SINK 及 SOURCE，其定义与输入点回路等效电路配线图，请参阅英文版之 Figure 11 及 Figure 12。

◆继电器输出回路配线

详细配线图请参阅英文版之 Figure 13。

- | | |
|---|---------------|
| ① 直流电源供给 | ② 紧急停止：使用外部开关 |
| ③ 保险丝：使用 5 ~ 10A 的保险丝容量于输出接点的共享点，保护输出点回路。 | |
| ④ 突波吸收二极管：可增加接点寿命。
1. DC 负载电源之二极管抑制：功率较小时使用（请参阅英文版之 Figure 14）
2. DC 负载电源之二极管+Zener 抑制：大功率且 On/Off 频繁时使用（请参阅英文版之 Figure 15） | |
| ⑤ 白炽灯（电阻性负载） | ⑥ 交流电源供给 |
| ⑦ 互斥输出：例如，将 Y4 与 Y5 用以控制对应马达的正转及反转，使外部电路形成互锁，配合 TP04P 内部程序，确保任何异常突发状况发生时，均有安全的保护措施。 | |
| ⑧ 指示灯：氖灯 | |
| ⑨ 突波吸收器：可减少交流负载上的噪声（请参阅英文版之 Figure 16） | |

◆模拟输入外部配线（请参阅英文版之 Figure 17 和 Figure 18）

- 注 1：模拟输入请与其它电源隔离
注 2：如果连接电流讯号时，V3+ 与 I3+ 端子请务必短路。
注 3：如果输入电压有涟波造成配线受噪声干扰时，请连接 0.1~0.47 μ F 25V 之电容。
注 4：如果噪声过大，请将 FE 及接地端子连接。
注 5：请将电源模块的接地端子及 AD 仿真量信号输入端之 FE 连接到系统接地点，再将系统接地点作第三种接地或接到配电箱之机壳上。

◆模拟输出外部配线（请参阅英文版之 Figure 19 和 Figure 20）

- 注 1：模拟输出请与其它电源隔离
注 2：如果负载之输入端涟波太大造成配线受噪声干扰时，请连接 0.1~0.47 μ F 25V 之电容
注 3：如果噪声过大，请将 FE 及接地端子连接。
注 4：请将电源模块的 FE 及 DA 仿真量信号输出端之 FE 连接到系统接地点，再将系统接地点作第三种接地或接到配电箱之机壳上。

◆温度测量外部配线（请参阅英文版之 Figure 21）

- 注 1：使用于模拟输入的配线应采用温度传感器之连接线或双绞隔离线，且应与其它电源或可能引起噪声之接线分开。
注 2：如果噪声过大，请将 FE 及接地端子连接。
注 3：请将电源模块的接地端子及温度感测信号输入端之 FE 连接到系统接地点，再将系统接地点作第三种接地或接到配电箱之机壳上。
注意：空端子请勿配线。

◆RS-485 建议接线

详细接线图请参阅英文版之 Figure 22。

- | | | |
|------|------|--------|
| ① 主站 | ② 从站 | ③ 终端电阻 |
|------|------|--------|

附注：1. 终端电阻建议连接于主站及最后一台从站上，且其电阻值建议为 120 Ω 。
2. 为确保联机质量，线材建议使用具有双层遮蔽线之通讯双绞线（20AWG）。

■通讯连接线配线图

- TP04P 程序规划 - 使用 USB
- 请使用 USB A 公转 B 公之连接电缆线，详细图面请参阅英文版之 Figure 23。

■电池寿命

温度 (°C)	-20	0	20	60
寿命 (年)	2.0	2.5	2.7	2.8

■万年历的精度 (秒 / 月)

温度 (°C/°F)	0/32	25/77	55/131
最大误差 (秒)	-117	52	-132